

WINDOW INSTALLATION GUIDE



GoodHome 

EAN Numbers

5036581077617	5036581078027	5036581078553
5036581077624	5036581078034	5036581078560
5036581077631	5036581078041	5036581078577
5036581077648	5036581078058	5036581078584
5036581077655	5036581078065	5036581078591
5036581077662	5036581078072	5036581078607
5036581077679	5036581078447	5036581078614
5036581077686	5036581078454	5036581078621
5036581077693	5036581078461	5036581074227
5036581077709	5036581078478	5036581074234
5036581077716	5036581078485	5036581074241
5036581077723	5036581078492	5036581074258
5036581077730	5036581078508	5036581074883
5036581077747	5036581078515	5036581074890
5036581077754	5036581078164	5036581074906
5036581077761	5036581078171	5036581074913
5036581077778	5036581078188	5036581076412
5036581077785	5036581078195	5036581076429
5036581077792	5036581078201	5036581076436
5036581077808	5036581078218	5036581076443
5036581077884	5036581078225	5036581080242
5036581077891	5036581078232	5036581080259
5036581077907	5036581078249	5036581080266
5036581077914	5036581078256	5036581080273
5036581077921	5036581078263	5036581083571
5036581077938	5036581078270	5036581083588
5036581077945	5036581078287	5036581083595
5036581077952	5036581078294	5036581083601
5036581077969	5036581078300	5036581085568
5036581077976	5036581078317	5036581085575
5036581077983	5036581078324	5036581085605
5036581077990	5036581078331	5036581085582
5036581078003	5036581078348	5036581085599
5036581078010	5036581078355	5036581085612

Welcome to your new window

Thank you for choosing a new energy efficient window from GoodHome.

Your new window has been manufactured to the highest quality standards and is guaranteed for 15 years.

Your window will arrive unglazed and it is important that you stack the window and glass in a vertical position - TO prevent your window and glass being damaged stack on flexible material between surfaces, such as wooden blocks.

Your window is delivered fully fabricated and should retain the protective film until all building works are complete.

Your delivery contains:-

- 1. PVC-U window** - the window will have corner blocks attached. These are there for protection - remove these prior to installation - see No 1.
- 2. Handle** - already attached to the window. This is fitted with handle mesh for protection - see No 2 .
- 3. Trickle vents** - these are taped to the window - see No. 3.
- 4. Glazing packers, cill and cill end caps** - these are taped to the window cill - see No 4.

Prior to installation please ensure that your new window has been checked for imperfections or any damage.

Please report any issues within 48 hours of delivery.



Protective corner blocks



Window handle



Window trickle vents

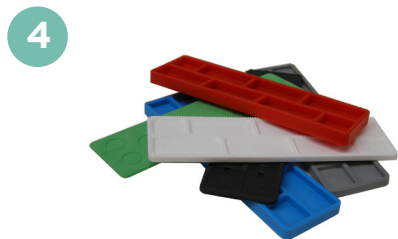

Glazing packers, cill and cill end caps

Fitting the new frame

Please read through all of this instruction guide before starting.

1

Remove the old frame

Once the old frame has been removed, brush away any loose debris or cement, leaving a clean opening ready to receive the new frame.

2

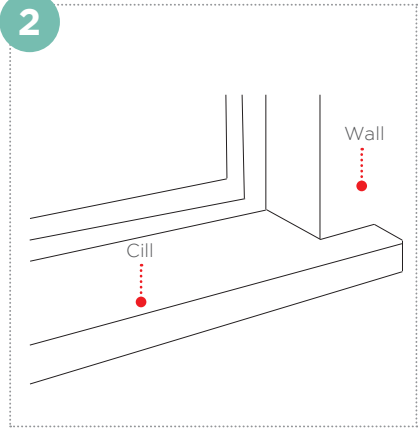

Frame with a cill

If you are fitting a frame with a cill, first decide if you are going to run the cill around the brickwork or cut it flush to the finished width of the hole (see above).

Whichever way you decide to do it, cut the cill to size with a fine toothed saw to fit tightly back to the inside edge where the old frame sat. You may have to remove the tongue of the internal window board first.

Affixing a cill

Once the cill has been cut to size, apply a line of sealant along the cill upstand and across the frame platform at each end. Screw them together, through the bottom frame section along the centre line and into the cill.

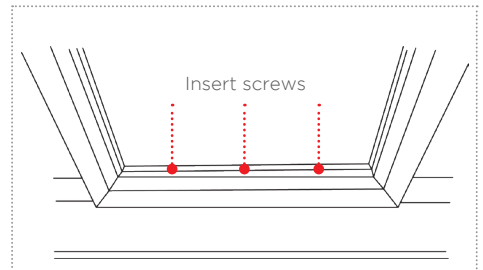

3

Expanders

Your new window should have a gap of around 5mm all around it to make sure it fits into the aperture - you can add frame extenders if you need to.

If your new window isn't quite big enough, you can add a total of 15, 20 or 35mm to the width or depth by attaching frame extenders.

Please note: Do not forget to remove the corner protectors prior to installation

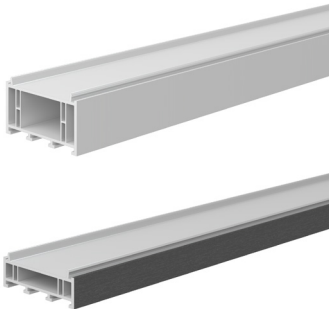

Window expanders

4

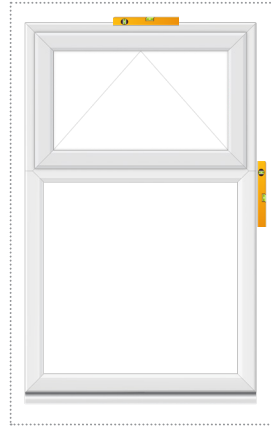

Insert new frame

Offer the frame into the opening and using a spirit level, ensure the frame is level, vertical and not twisted before wedging into position.

Centralise it and insert packers underneath to level it and maintain the 5mm expansion gap.

5

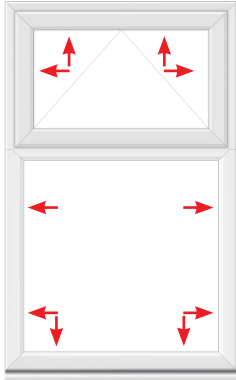

Affix new frame

1. Remove any packaging from the new frame and screw the cill onto the bottom of the frame. Make sure you select a screw that doesn't penetrate the inner skin of the frame.
2. Seal the ends of the cill and frame to prevent moisture tracking along the cills into the brickwork.
3. Position the frame into the prepared aperture. Centralise it and use packers to ensure that it is level and to maintain a 5mm expansion gap.
4. Once the frame is level drill fixing holes into the frame sides. These should be drilled 150mm from the top and bottom corners and 600mm in between (a minimum of 2 fixings per side).
5. Fix the side of the window frame to the wall. To avoid distortion to the frame and maintain the 5mm expansion gap use packers (do not overtighten the fixings).
6. On wider frames ensure you fix the top and bottom of the frames. Ensure that the top and bottom fixings are sealed with silicone to prevent moisture absorbing into the brickwork.
7. When finished ensure you clean any brick dust from your new window frame.
8. For optimum thermal and acoustic performance, it is critical that the gap between the window or door product and the aperture is fully insulated using a suitable expanding foam or expanding foam tape.

Glazing

1

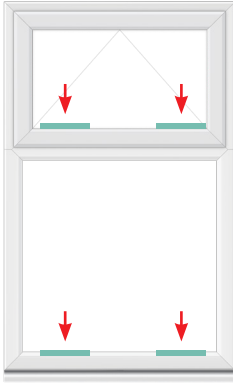

How to glaze the new window

Starting with one of the longest beads first, remove the glazing beads by pushing a sharp chisel or a rigid paint scraper between the bead and the frame joint at approximately the centre point. A sharp tap on the butt of the tool should allow the bead to be freed. It is most important to refit the beads in the same positions as they were removed, they may vary in length slightly, due to the manufacturing process.

1. Place into position the glass packers approximately 100mm in from each corner (intermediate packers should be used if the double glazed unit is wider than 1200mm).
2. Place the double glazed unit into the frame ensuring correct positioning on the glass packers.
3. Starting on one of the shortest lengths, fit 3 of the beads moving around the frame using a rubber mallet, finally fitting the last bead by bending it into position.

N.B. It is always best to leave one of the longer beads until last as a long bead will locate and bend more easily.

2

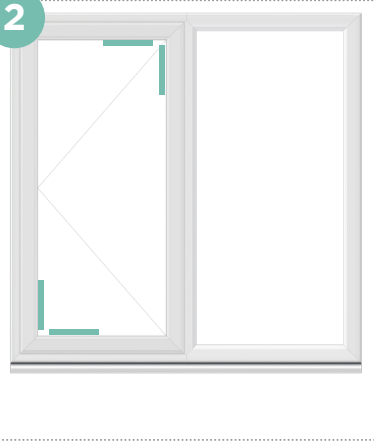

Toeing and heeling

PVC-U opening windows (sash) are heavy, and although the dead weight is supported on the hinge side when it is opened, there is nothing on the lock side to support the weight, and without the procedure of toeing and heeling the door will drop on the handle side. To prevent a sash dropping, the glass has to be braced diagonally corner to corner (see diagram) by the insertion of plastic packers slipped in the gap between the glass or panel and frame.

How to toe and heel

The door or sash on the lock side should be raised to the desired height and squared up with the door frame. On the hinge side place the packers at the bottom corner, whilst on the lock side, the packers go at the top (opposite) corner - place a dab of silicone under the packers on the door sides to stop the packers dropping. It is advisable to use a glazing shovel when lifting the glass or panel. The packers should be placed approximately 150mm from the edge of the frame.

Adjustments

1

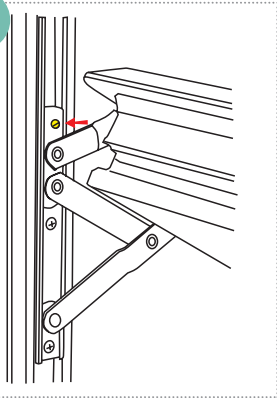

Window hinges

Generally the window hinges require no adjustment. However, should you wish to adjust the tension on the friction stay, this can be achieved by screwing the brass screw, set in the black plastic pad, in or out to increase or decrease the tension. The adjustment screw can be accessed by opening the vent.

2

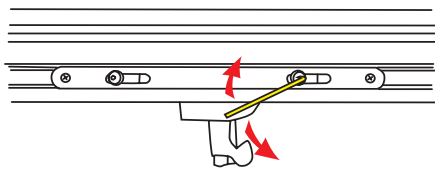

Window locking mushroom cams

The cams on the window locking mechanism can be adjusted with an Allen key that is located in the centre of the mushroom cams. The cams are eccentric and can be turned to increase or decrease the closing pressure of the mechanism. They should also be used to adjust the cams if you experience difficulty closing the window vent. This is usually caused by the pressure being too tight and the cams grinding onto the keeps.

Finishing

Clean the external surfaces to remove the dirt and grit.

Apply a strip of masking tape to the frame perimeter. Apply a smooth bead of silicone sealant between the frame and brick work. Before the sealant sets, remove the masking tape to create a neat finish. It is important to remember to seal below the external cill.

Trims and profiles come in lots of different shapes and sizes to cover sealant and fixings. They'll give you a neat, professional finish, inside and out.

You can cover wider gaps around the outside of the window with a PVC-U

scotia trim. Do this by sealing the frame behind the trim with frame sealant. You can then stick the trim in place with more frame sealant.

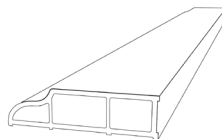

You have finished!

Once you have installed your new window, open and close it to ensure that it is working correctly.

Top tips looking after your windows

Our top tips to keep your windows in the best condition, we recommend...

1. That you carry out routine maintenance on your windows at least twice a year. In areas of high exposure, you may want to do this more frequently.
2. All parts of your new windows that are exposed when closed, should be washed down with warm soapy water using a soft cloth, then dried thoroughly.
3. Any parts that are exposed when the window is open, should simply be wiped clean, removing any grime, dirt, insect remains or old lubricant.
4. You avoid any cleaning agents that have ammonia in them or that are abrasive, particularly on handles and other metal fittings.
5. Special attention is paid to keep drainage channels clear and free from any blockages.
6. That any moving parts and fixings are treated as follows:
 - The application of light oil, to keep the locking mechanism in good working order.
 - A suitable acid and resin free grease should be used on sliding bars, gears and face plates.
 - Maintenance of friction stays is important and we recommend that you follow the guidelines for lubrication and adjustment.

Do...

- Wash down the PVC-U at least twice a year with warm soapy water and wipe it dry.
- Regularly clean the glass with a clear liquid spray glass cleaner.

Don't...

- Paint PVC-U window frames.
- Use paste or cream cleaners which can be mildly abrasive.
- Use any type of bleach, solvent or adhesive.

Friction Hinges

Maintenance is important but straightforward. Keep the friction stay track free from dirt and grime and keep the hinge mechanism clean. Lubricate the metal parts regularly with light oil, concentrating on the pivot points. Friction can be increased or decreased by adjustment of a screw. Turn in a clockwise direction to increase friction. Take care not to over tighten.

Egress Friction Hinges

In order to facilitate a maximum clear opening, egress hinges may be fitted. In most cases this will be an upstairs window and allows the window to be opened to 90°. Some egress hinges combine the opening facility with an easy clean system, whereby the vent can be slid sideways to allow external cleaning to be carried out from inside. To utilise the easy clean facility, open the window normally, then press and hold down the button on both hinges to release the restrictor hinge. Slide the vent across to allow egress.

Window Locking Mechanisms

Windows fitted with either an Espagnolette or Shoot Bolt locking system will allow the window to remain partly open at night to facilitate ventilation.

To engage the window in its night vent position, open the window to approximately 15mm and then return the handle to its locking position. You may feel slight resistance so do not try to force the handle, simply move the window slightly until you find a point where there is no resistance and close. Check the window is held securely in the night vent position by pushing gently on the vent - if held securely it should not move. Maintenance of locking systems is simple: apply light oil to the moving parts, once a year. Similarly, a little grease should be applied to the locking slots to facilitate smooth running.

Ventilation Control

Windows are fitted with a trickle ventilation unit, located at the top of the sash. This is designed so that you can control ventilation and minimise any build up of condensation. Simply open or close the ventilator. No maintenance is required.

Handles

Windows can be fitted with key locking, push to open handles. An easy to use system, yet secure and long lasting. To operate, simply press the thumb button, turn through 90° and push the window to the desired angle. To close, reverse the procedure by pulling the window closed and turning the handle back to its original position, thus engaging it automatically. Handles can be deadlocked by using the key provided.

Guarantee conditions

We take special care to select high quality materials and use manufacturing techniques that allow us to create products incorporating design and durability. This GoodHome product (has a manufacturer's guarantee of 15 years against manufacturing defects, from the date of purchase (if bought in store) or date of delivery (if bought online), at no additional cost for normal (non-professional or commercial) household use.

To make a claim under this guarantee, you must present your proof of purchase (such as a sales receipt, purchase invoice or other evidence admissible under applicable law), please keep your proof of purchase in a safe place. For this guarantee to apply, the product you purchased must be new, it will not apply to second hand or display products. Unless stated otherwise by applicable law, any replacement product issued under this guarantee will only be guaranteed until expiry of the original period guarantee period.

This guarantee covers product failures and malfunctions provided the product was used for the purpose for which it is intended and subject to installation, cleaning, care and maintenance in accordance with the information contained in these terms and conditions, in the user manual and standard practice, provided that standard practice does not conflict with the user manual.

This guarantee does not cover defects and damage caused by normal wear and tear or damage that could be the

result of improper use, faulty installation or assembly, neglect, accident, misuse, or modification of the product. Unless stated otherwise by applicable law, this guarantee will not cover, in any case, ancillary costs (shipping, movement, costs of uninstalling and reinstalling, labour etc), or direct and indirect damage.

If the product is defective, we will, within a reasonable time, repair it or replace it.

Rights under this guarantee are enforceable in the country in which you purchased this product. Guarantee related queries should be addressed to the store you purchased this product from.

The guarantee is in addition to and does not affect your statutory rights.

Manufacturer:

Kingfisher International Products Limited
3 Sheldon Square, London W26PX
United Kingdom

Kingfisher International Products B.V.
Rapenburgerstraat 175E
1011 VM Amsterdam, The Netherlands

Distributor:

B&Q plc. Chandlers Ford. Hants
SO53 3LE, United Kingdom
www.diy.com

SFD Limited, Trade House, Mead
Avenue, Yeovil BA22 8RT,
United Kingdom
www.screwfix.com



(EN) DECLARATION OF PERFORMANCE

No **DOP C79782 5036581074227 1**

EN - Unique identification code of the Product type : **EAN 5036581074227**

EN - By extension, this declaration of performance also applies to any EAN product codes detailed in Appendix 1

- Product name – **PVC-U Tilt and Turn casement Windows**
- Product model – **Spectus Elite 70**

EN - Intended use: **Tilt and Turn casement Windows to be used in domestic and commercial locations.**

(Name, registered trade name or registered trademark and contact address of the manufacturer as required under Article 11(5))

Kingfisher International Products B.V., Rapenburgerstraat 175E, 1011 VM Amsterdam, The Netherlands

(System or systems of assessment and verification of constancy of performance of the construction product as set out in CPR, Annex V.)

EN - System(s) of assessment and verification of constancy of performance: **System 3**

(Relevant EN standards (hEN) relevant harmonised standards used, or references to the specifications in relation to which performance is declared)

EN - Harmonized standard: **EN 14351-1:2006+A2:2016 Annex ZA AVCP Level 3**

EN - Notified bodies: 0086, report number 12269

EN - Declared performance/s:

EN - Essential Characteristics	EN - Performance	EN - Standard / EAD FR - Norme / DEE
FR - Caractéristiques Essentielles	FR - Performance	PL - Norma / EDO RO – Standard / DEE
PL - Zasadnicze Charakterystyki	PL - Właściwości użytkowe	DE - Norm / EBD TR - Standart / EAD
RO - Caracteristicile Esențiale	RO - Performanța	ES - Norma / DEE PT - Norma / DAE
DE - Wesentlichen Merkmale	DE - Leistung	
TR - Temel Karakteristikler	TR - Performans	
ES - Características Esenciales	ES - Prestación	
PT - Características Essenciais	PT - Desempenho	
Watertightness	NPD	EN 1027
Dangerous substances	None	EN 14351-1:2006
Resistance to wind load	NPD	EN 12211
Load-bearing capacity of safety devices	Passed	EN 948
Acoustic performance	NPD	EN 140-3
Thermal transmittance	1.3 W/m²K	EN ISO 10077-1 & 10077-2 or 12567-1 & 12567-2
Radiation properties	NPD	EN 410
Air permeability	NPD	EN 1026

EN - The performance of the product identified above is in conformity with the set of declared performance/s. This declaration of performance is issued, in accordance with Regulation (EU) No 305/2011, under the sole responsibility of the manufacturer identified above

Signed for and on behalf of

**Kingfisher International Products B.V.,
Rapenburgerstraat 175E,
1011 VM Amsterdam,
The Netherlands**

Eric Capotummino - Group Quality Director

[28/02/2020]

Appendix 1

List of EAN's:

5036581074227, 5036581074234, 5036581074241, 5036581074258, 5036581074883, 5036581074890, 5036581074906, 5036581074913, 5036581076412, 5036581076429, 5036581076436, 5036581076443, 5036581077617, 5036581077624, 5036581077631, 5036581077648, 5036581077655, 5036581077662, 5036581077679, 5036581077686, 5036581077693, 5036581077709, 5036581077716, 5036581077723, 5036581077730, 5036581077747, 5036581077754, 5036581077761, 5036581077778, 5036581077785, 5036581077792, 5036581077808, 5036581077884, 5036581077891, 5036581077907, 5036581077914, 5036581077921, 5036581077938, 5036581077945, 5036581077952, 5036581077969, 5036581077976, 5036581077983, 5036581077990, 5036581078003, 5036581078010, 5036581078027, 5036581078034, 5036581078041, 5036581078058, 5036581078065, 5036581078072, 5036581078164, 5036581078171, 5036581078188, 5036581078195, 5036581078201, 5036581078218, 5036581078225, 5036581078232, 5036581078249, 5036581078256, 5036581078263, 5036581078270, 5036581078287, 5036581078294, 5036581078300, 5036581078317, 5036581078324, 5036581078331, 5036581078348, 5036581078355, 5036581078447, 5036581078454, 5036581078461, 5036581078478, 5036581078485, 5036581078492, 5036581078508, 5036581078515, 5036581078553, 5036581078560, 5036581078577, 5036581078584, 5036581078591, 5036581078607, 5036581078614, 5036581078621, 5036581080242, 5036581080259, 5036581080266, 5036581080273, 5036581083571, 5036581083588, 5036581083595, 5036581083601, 5036581085568, 5036581085575, 5036581085582, 5036581085599, 5036581085605, 5036581085612.