

ALUMINIUM DOOR INSTALLATION GUIDE



EAN Numbers

Bi-Folding doors

5060456211004

5060456211011

5060456211028

5060456211035

5060456211042

5060456211059

5060456210014

5060456210007

5060456210038

5060456210021

5060456210052

5060456210045

5060456210069

5060456210076

French doors

5036581078775

5036581078782

5036581078799

Welcome to your new door

Thank you for choosing a new energy efficient door from GoodHome. Your new door has been manufactured to the highest quality standards and is guaranteed for 15 years.

Your door will arrive unglazed and it is important that you stack the door in a vertical position - prevent your door being damaged by stacking on flexible material between surfaces, such as wooden blocks.

Your door is delivered fully fabricated and should retain the protective film until all building works are complete.

Your delivery contains:-

- 1. Door** - the door will have corner blocks attached. These are there for protection - remove these prior to installation - see No 1.
- 2. Handle** - already attached to the door. This is fitted with handle mesh for protection - see No 2.
- 3. Trickle vents** - these are taped to the door - see No 3.
- 4. Glazing packers, cill and cill end caps** - these are in a plastic bag - see No 4.

Prior to installation please ensure that your new door has been checked for imperfections or any damage.

Please report any issues within 48 hours of delivery.



Protective corner blocks

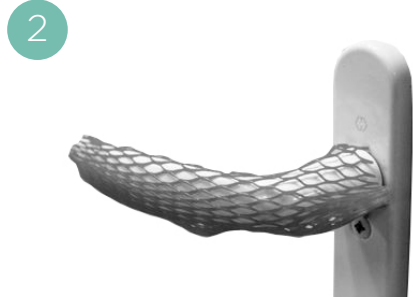

Door handle



Trickle vents



Glazing packers, cill and cill end caps

Fitting the new frame

1

Please read through all of this instruction guide before starting.

Remove the old frame

Before removing your existing frame double check that your new frame fits into the existing aperture.

Once the old frame has been removed, brush away any loose debris or cement, leaving a clean opening ready to receive the new frame.

2

Frame with a cill

If you are fitting a frame with a cill, first decide if you are going to run the cill around the brickwork or cut it flush to the finished width of the hole.

Whichever way you decide to do it, cut the cill to size with a fine toothed saw to fit tightly back to the inside edge where the old frame sat. You may have to remove the tongue of the internal window board first.

Affixing a cill

Once the cill has been cut to size, apply a line of sealant along the cill upstand and across the frame platform at each end. Screw them together, through the bottom frame section along the centre line and into the cill.

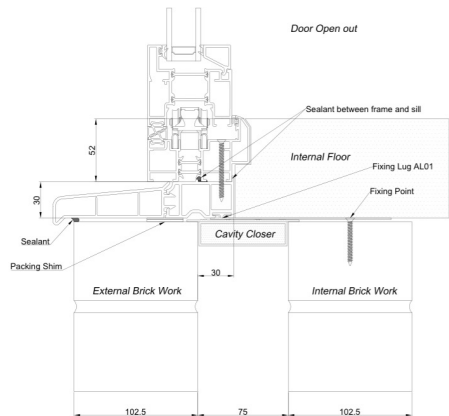
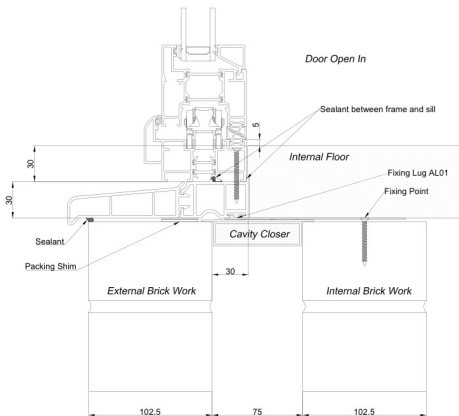

3



Insert new frame

Offer the frame into the opening and using a spirit level, ensure the frame is level, vertical and not twisted before wedging into position.

Centralise it and insert packers underneath to level it and maintain the 5mm expansion gap.

4

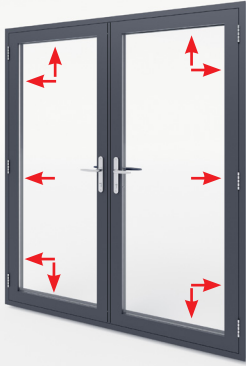

Affix new frame

1. Remove any packaging from the new frame and screw the cill onto the bottom of the frame. Make sure you select a screw that doesn't penetrate the inner skin of the frame.
2. Seal the ends of the cill and frame to prevent moisture tracking along the cills into the brickwork.
3. Position the frame into the prepared aperture. Centralise it and use packers to ensure that it is level and to maintain a 5mm expansion gap.
4. Once the frame is level drill fixing holes into the frame sides. These should be drilled 150mm from the top and bottom corners and 600mm inbetween (a minimum of 2 fixings per side).
5. Fix the side of the frame to the wall. To avoid distortion to the frame and maintain the 5mm expansion gap use packers (do not overtighten the fixings).
6. On wider frames ensure you fix the top and bottom of the frames. Ensure that the top and bottom fixings are sealed with silicone to prevent moisture absorbing into the brickwork.
7. When finished ensure you clean any brick dust from your new frame.
8. For optimum thermal and acoustic performance, it is critical that the gap between the door product and the aperture is fully insulated using a suitable expanding foam or expanding foam tape.

Glazing



How to glaze the new door

Starting with one of the longest beads first, remove the glazing beads by pushing a sharp chisel or a rigid paint scraper between the bead and the frame joint at approximately the centre point. A sharp tap on the butt of the tool should allow the bead to be freed. It is most important to refit the beads in the same positions as they were removed, they may vary in length slightly, due to the manufacturing process.

1. Place into position the glass packers approximately 100mm in from each corner (intermediate packers should be used if the double glazed unit is wider than 1200mm).
2. Place the double glazed unit into the frame ensuring correct positioning on the glass packers.
3. Starting on one of the shortest lengths, fit 3 of the beads moving around the frame using a rubber mallet, finally fitting the last bead by bending it into position.

N.B. It is always best to leave one of the longer beads until last as a long bead will locate and bend more easily.

Toe and heeling

Opening doors (sash) are heavy, and although the dead weight is supported on the hinge side when it is opened, there is nothing on the lock side to support the weight, and without the procedure of toe and heeling the door will drop on the handle side. To prevent a sash dropping, the glass has to be braced diagonally corner to corner (see diagram) by the insertion of plastic packers slipped in the gap between the glass or panel and frame.

How to toe and heel

The door or sash on the lock side should be raised to the desired height and squared up with the door frame. On the hinge side place the packers at the bottom corner, whilst on the lock side, the packers go at the top (opposite) corner - place a dab of silicone under the packers on the door sides to stop the packers dropping. It is advisable to use a glazing shovel when lifting the glass or panel. The packers should be placed approximately 150mm from the edge of the frame.

Door hinge

- On the main lock, ensure that the latch is catching and the handle throw allows the hooks to move into position and the key turns the cylinder. On the shoot-bolt locks, ensure the handle can be turned freely and the bolts engage smoothly with the frame.
- Check the perimeter gaskets on the sashes are providing an even seal and constant and even gasket line.
- In case the sash-frame or sash-sash clearance is causing interference or is deemed to be too small, the plastic packing strips under each hinge can be removed to increase the closing gaps.
- Compression on the lock can be adjusted by rotating the rollers in the required position.
- Further adjustment is available via keep positions.
- It is recommend to undertake any adjustments after the final glazing.

Lock and Keep adjustment

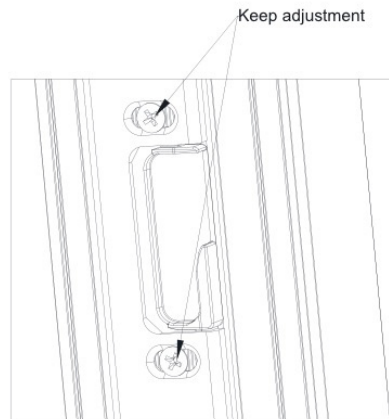
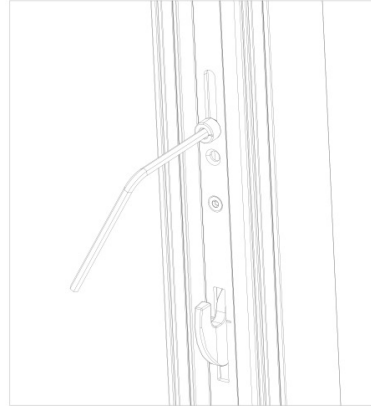

Bi-fold door survey and installation

1

General

BS 8213-4:2007 Code of Practice for the Survey and Installation of Windows and External Doorsets gives recommendations for the surveying and installation of non-load bearing windows and external doorsets, to be installed vertically (within 15°) into the external face of buildings.

It gives guidance on the good practices for successful surveying and installation. All aspects of this document should be followed with particular attention given to the product's suitability for its location and the presence of any dead loads. Wherever possible the survey should identify any necessary variations to the standard installation techniques such as lug fixing or direct fixing. Fixing methods are determined by the construction of the structural opening and the method of drainage. If you are at all unsure then please contact your supplier. Any finished floor level should clear the bottom of a sash (gasket) by at least 5mm in closed and open position, to avoid any interference caused by installation tolerances and unevenness.

Personal protective equipment should be worn at all times during installation and on building sites. In order to protect surroundings from dust and debris, it is recommended to use dustsheet where possible.

2

Preparing the structural opening

Check that the opening is the correct size for the new frame (N.B.: For replacement work this should be done prior to removal). Check that any DPC's are sound and not "bridged" by any render or plaster. Check for the practicality of fixings to the lintels. The base of the opening must be constructed of suitable structural material, e.g.: brick, block, stone, timber etc.

3

Installing the Frame

Fixing the Cill :-The method shown requires the cill to be fitted to the base of the opening making sure that the base is clean of loose debris and the DPC is intact. The method shows lug fixing over cavity closer. The cill is levelled by using appropriate shims placed under each fixing centre. Then fix with the appropriate frame fixings 200mm from each end at a maximum of 600mm centres (In accordance with BS 8213-4:2007). Apply silicone as shown between frame and cill. Lift the frame onto the cill and adjust the frame in the opening to be square, plumb and straight. Use temporary wedges to set the frame square in the opening. Wedge shims between frame and brickwork to achieve final positioning of frame. Use diagonal measurement across opposite corners of the outer frame to check.

Installing the frame cont...

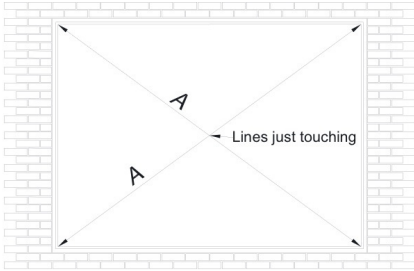

Check the frame is in square by measuring the diagonals from opposite corners.

Finally fix the frame to cill using 45-50mm self-tapping PVC screws, by pre-drilling aluminium frame section. Countersink if appropriate and/or place gasket back in to position.

Fixing cill

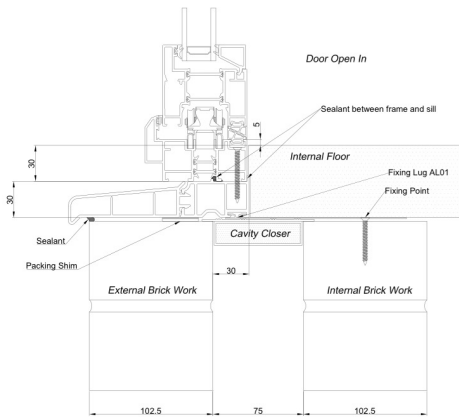

With frame in place, use suitable fixing method to fix frame jambs and frame head to the brickwork.

Fixings should be 200mm from top and bottom corners and no more than 600mm centres in between. Use fixing lugs for cill fixing and outer-frame (jambs and head) fixing.

Make sure that in line with each fixing a shim is placed to avoid any distortion of the frame during tightening the screws.

Ensure that head is fixed level with no bow in either plane.

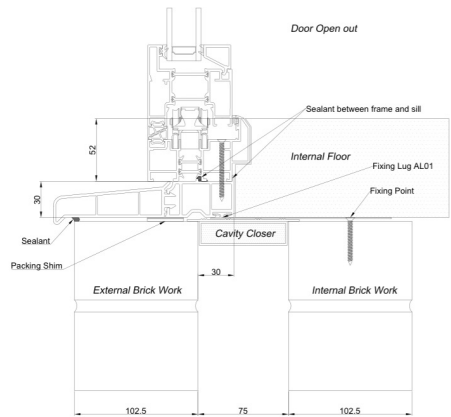

Finally check that the door, runs, folds, closes and locks properly and is secure. The bottom track should be cleared of any debris and mortar prior to operating the door using a builders' vacuum or other suitable cleaning equipment. This is to ensure that no damage is caused to the wheels and track.

On the main lock, ensure that the latch is catching and the handle throw allows the hooks to move in to position and the key turns the cylinder. On the shoot-bolt locks, ensure the handle can be turned freely and the bolts engage smoothly with the frame.

Check the perimeter gaskets on the sashes are providing an even seal and constant and even gasket line. In case the sash-frame or sash-sash clearance is causing interference or is deemed to be too small, the plastic packing strips under each hinge can be removed to increase the closing gaps. Compression on the lock can be adjusted by rotating the rollers in the required position.

Further adjustment is available via keep positions.

It is recommend to undertake any adjustments after the final glazing.

Lock and keep adjustment

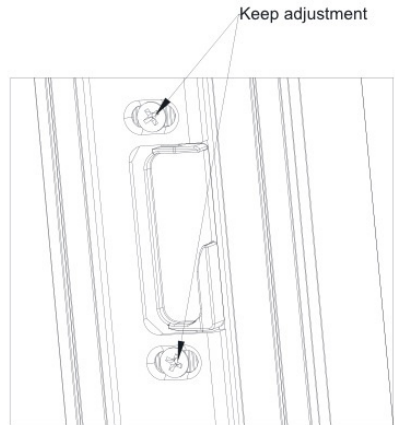
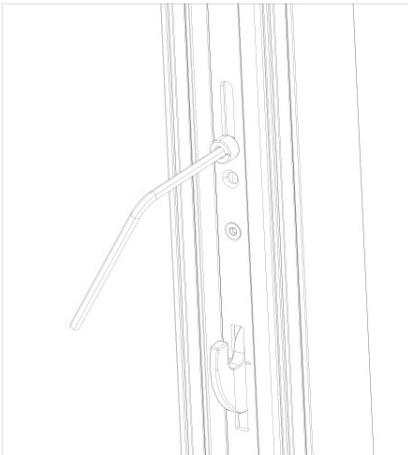

4

Glazing

Bridge packers are clipped into position as shown. Additional glazing packers should be used to properly toe and heeling all sashes of the door. When toe and heel, ensure each sash is not pushed out of alignment. Use toe and heeling to align sashes correctly so that they are running freely, provide even gasket compression, clearances and locking. Packers for final fix are to be placed into

top corners where shown. Make sure the final fix packers do not work against the toe & heel packers. To ensure safe working, glass suckers should be used. PVC beads are inserted by using a soft tipped mallet and aluminium beads are inserted pushing in the wedge gaskets provided.

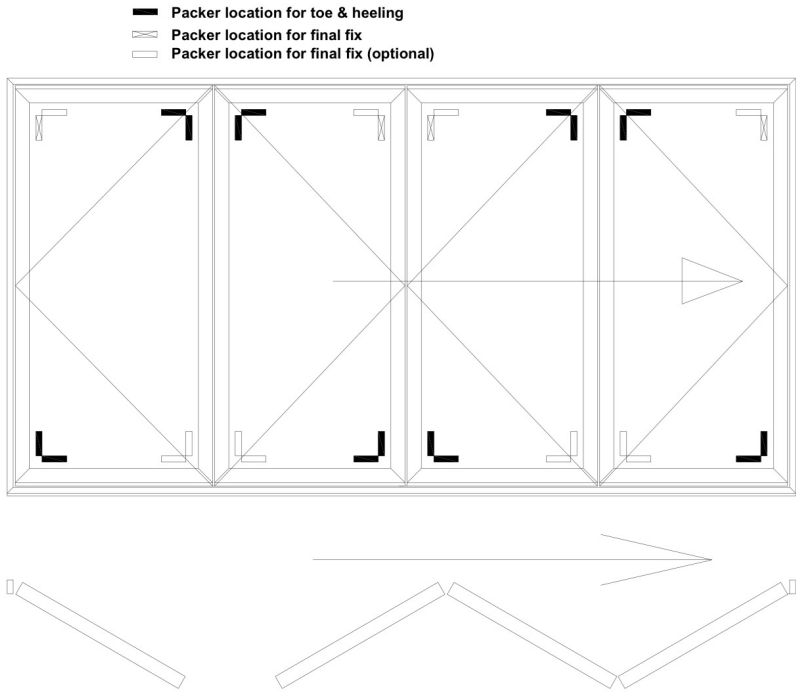

2

Perimeter sealing

The purpose of perimeter sealants is to repel water and prevent air leakage in the face of differential movement between the aperture and the doorset. It is important to prevent water entering between the frame and the structure from the outside, but also to seal air gaps on the inside. This is to prevent moist air reaching over the insulation and creating condensation.

Suitable sealants exhibit and retain flexibility and adhesion over this period. The movement class for the sealant will depend on the substrate material, the frame material and the dimensions of the joint between the frame and the opening.

It is advisable to clean down the frame before sealing the perimeter.

The gap between the outer frame and structure must be sealed using a suitable external grade sealant. 5-6mm gaps can be filled with sealant alone, however larger gaps may require the use of foam backing strips.

In some cases a small cover trim will be required to produce a neat finish.

If access allows, the gap below the cill should be pointed with sealant. If this is not possible, ensure that the cill has been set on a suitable silicone or mortar bed.

Finishing

Clean the external surfaces to remove the dirt and grit.

Apply a strip of masking tape to the frame perimeter. Apply a smooth bead of silicone sealant between the frame and brick work. Before the sealant sets, remove the masking tape to create a neat finish. It is important to remember to seal below the external cill.

Trims and profiles come in lots of different shapes and sizes to cover sealant and fixings. They'll give you a neat, professional finish, inside and out.

You can cover wider gaps around the outside of the door with a PVCu scotia trim. Do this by sealing the frame behind the trim with frame sealant. You can then stick the trim in place with more frame sealant.

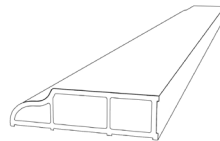

You have finished!

Once you have installed your new door, open and close it to ensure that it is working correctly.

Top tips looking after your doors

Our top tips to keep your doors in the best condition, we recommend...

- That you carry out routine maintenance on your doors at least twice a year. In areas of high exposure, you may want to do this more frequently.
- All parts of your new doors that are exposed when closed, should be washed down with warm soapy water using a soft cloth, then dried thoroughly.
- Any parts that are exposed when the window is open, should simply be wiped clean, removing any grime, dirt, insect remains or old lubricant.
- You avoid any cleaning agents that have ammonia in them or that are abrasive, particularly on handles and other metal fittings.
- Special attention is paid to keep drainage channels clear and free from any blockages.
- That any moving parts and fixings are treated as follows:
 - The application of light oil, to keep the locking mechanism in good working order.
 - A suitable acid and resin free grease should be used on sliding bars, gears and face plates.
 - Maintenance of friction stays is important and we recommend that you follow the guidelines for lubrication and adjustment.

Locking

To operate the lock, insert the key into the cylinder. Rotate the handle upwards and turn the key for one complete revolution to activate the deadbolt, which locks the whole mechanism. Release the handle.

Unlocking

Insert the key into the cylinder and disengage the deadbolt by turning one complete revolution. Depress the handle and open the door. Where a split spindle is fitted in addition, after you have depressed the handle, turn the key a further quarter revolution to release the latch.

Guarantee conditions

We take special care to select high quality materials and use manufacturing techniques that allow us to create products incorporating design and durability. This GoodHome product (has a manufacturer's guarantee of 15 years against manufacturing defects, from the date of purchase (if bought in store) or date of delivery (if bought online), at no additional cost for normal (non-professional or commercial) household use.

To make a claim under this guarantee, you must present your proof of purchase (such as a sales receipt, purchase invoice or other evidence admissible under applicable law), please keep your proof of purchase in a safe place. For this guarantee to apply, the product you purchased must be new, it will not apply to second hand or display products. Unless stated otherwise by applicable law, any replacement product issued under this guarantee will only be guaranteed until expiry of the original period guarantee period.

This guarantee covers product failures and malfunctions provided the product was used for the purpose for which it is intended and subject to installation, cleaning, care and maintenance in accordance with the information contained in these terms and conditions, in the user manual and standard practice, provided that standard practice does not conflict with the user manual.

This guarantee does not cover defects and damage caused by normal wear and tear or damage that could be the

result of improper use, faulty installation or assembly, neglect, accident, misuse, or modification of the product. Unless stated otherwise by applicable law, this guarantee will not cover, in any case, ancillary costs (shipping, movement, costs of uninstalling and reinstalling, labour etc), or direct and indirect damage.

If the product is defective, we will, within a reasonable time, repair it or replace it.

Rights under this guarantee are enforceable in the country in which you purchased this product. Guarantee related queries should be addressed to the store you purchased this product from.

The guarantee is in addition to and does not affect your statutory rights.

Manufacturer:

Kingfisher International Products Limited
3 Sheldon Square, London W26PX
United Kingdom

Kingfisher International Products B.V.
Rapenburgerstraat 175E
1011 VM Amsterdam, The Netherlands

Distributor:

B&Q plc. Chandlers Ford. Hants
SO53 3LE, United Kingdom
www.diy.com

SFD Limited, Trade House, Mead
Avenue, Yeovil BA22 8RT,
United Kingdom
www.screwfix.com



(EN) DECLARATION OF PERFORMANCE

No **DOP_C79782_5036581078775_1**

EN - Unique identification code of the Product type : **EAN 5036581078775**

EN - By extension, this declaration of performance also applies to any EAN product codes detailed in Appendix 1

- Insert Product name – **Aluminium Double Leaf Doors**
- Insert Product model – **Stellar**

EN - Intended use: Aluminium Double Leaf Doors intended to be used in domestic and commercial locations

(Name, registered trade name or registered trademark and contact address of the manufacturer as required under Article 11(5))
Kingfisher International Products B.V., Rapenburgerstraat 175E, 1011 VM Amsterdam, The Netherlands

(System or systems of assessment and verification of constancy of performance of the construction product as set out in CPR, Annex V.)
EN - System(s) of assessment and verification of constancy of performance: **System 3**

(Relevant EN standards (hEN) relevant harmonised standards used, or references to the specifications in relation to which performance is declared)

EN - Harmonized standard: **EN 14351-1:2006+A2:2016**

(Notified Body lab name, number)

EN - Notified body/ies: 1806, report number CU20099-2

EN - Declared performance/s:

EN - Essential Characteristics FR - Caractéristiques Essentielles PL - Zasadnicze Charakterystyki RO - Caracteristicile Esențiale DE - Wesentlichen Merkmale TR - Temel Karakteristikler ES - Características Esenciales PT - Características Essenciais	EN - Performance FR - Performance PL - Właściwości użytkowe RO - Performanta DE - Leistung TR - Performans ES - Prestación PT - Desempenho	EN - Standard / EAD FR - Norme / DEE PL - Norma / EDO RO – Standard / DEE DE - Norm / EBD TR - Standart / EAD ES - Norma / DEE PT - Norma / DAE
Watertightness	NPD	BS EN 1027
Dangerous substances	None	BS EN 14351-1:2006
Resistance to wind load	NPD	BS EN 12211
Impact resistance	NPD	BS EN 13049
Load-bearing capacity of safety devices	None	BS EN 948
Ability to release	NPD	BS EN 179 & BS EN 1125
Acoustic performance	NPD	BS EN ISO 140-3
Thermal transmittance	1.5 W/m²K	EN ISO 10077-1 & 10077-2 or 12567-1 & prEN 12567-2
Radiation properties	NPD	EN 410
Air permeability	NPD	EN 1026

EN - The performance of the product identified above is in conformity with the set of declared performance/s. This declaration of performance is issued, in accordance with Regulation (EU) No 305/2011, under the sole responsibility of the manufacturer identified above

Signed for and on behalf of

**Kingfisher International Products B.V.,
Rapenburgerstraat 175E,
1011 VM Amsterdam,**

Eric Capotummino - Group Quality Director

[18/03/2020]

Appendix 1

List of EAN's:

5036581078775

5036581078782

5036581078799